

Insulation effect of air cavity in sand mold using 3D printing technology

Cheng-yang Deng¹, *Jin-wu Kang¹, Hao-long Shangguan¹, Tao Huang², Xiao-peng Zhang¹, Yong-yi Hu¹, and Tian-you Huang¹

1. School of Materials Science and Engineering, Tsinghua University, Key Laboratory for Advanced Materials Processing Technology, Ministry of Education, Beijing, China

2. Beijing DRUCK Technology Development Co. Ltd., China

Abstract: The insulation effect of the air cavity surrounding the riser in a 3D printed sand mold was studied. The influence of the air cavity on heat flux was theoretically analyzed. The results demonstrated that the heat flux of the air cavity in the 3D printed sand mold was significantly less than that of resin-bonded sand. The insulation effect of the air cavity in sand molds for a cylinder casting and a stress-frame casting were simulated using software COMSOL. The results illustrated that the air cavity could be used to insulate the riser and it was more suitable for a lower melting point metal casting. An air cavity with 10–15 mm width and 5–10 mm away from the riser can significantly prolong the solidification of the riser by over 10%. Meanwhile, the sand mold for the stress-frame was made by 3D printing technology and poured with aluminum alloy A356 melt. The experiment results showed that the presence of the air cavity led to a 12.5% increase of the solidification time of its riser.

Key words: 3D printing; sand mold; air cavity; insulation effect; riser

CLC numbers: TG231.6

Document code: A

Article ID: 1672-6421(2018)01-037-07

The riser is highly critical in casting processes as it serves as a feeding reservoir to prevent cavities caused by the shrinkage of liquid metal during the solidification process. Therefore, the riser is generally designed thicker than the hottest spots of castings; this necessitates a greater quantity of melt metal. Aiming to reduce the amount of metal usage and their cooling rate, the risers are usually insulated with materials, such as fiber-reinforced polymer composites, glass beads and etc., which have attracted the attention of a number of scholars^[1,2].

The study by Abdullah et al.^[3] demonstrated that the solidification time of melt in the riser surrounded with a type of riser sleeve, composed of sawdust and a slurry bonded with sodium silicate, was prolonged by 45%. Hussainy et al.^[4] claimed that the solidification time of a riser with an exothermic sleeve was 10% more than that of an insulated riser. Beckermann et al.^[5] reported that the solidification time of the riser surrounded with exothermic sleeve and insulating sleeve were increased by 55% and 44%, respectively. Song et al.^[6] optimized the ratio of graphite and clay of the exothermic riser

sleeve, and the solidification time of the molten steel in the riser surrounded with it was 38% longer than that in the riser insulated by a Fosco riser sleeve. Jin et al.^[7] developed a continuously heating method for insulating a riser and reduced the riser size by 50%.

Apart from these methods, air is widely used for insulation material for its low thermal conductivity [$0.02\text{--}0.1\text{ W}\cdot(\text{m}\cdot\text{K})^{-1}$] when the temperature varies from 293 K to 1,273 K^[8]. Al-Sanea and Zedan^[9] numerically studied the thermal characteristics of air in the cavity, and the simulation results proved the air cavity reduced almost 20% heat flux. Tong and Gerner^[10] reported that polystyrene bars with a multi cavity structure reduced heat flux by 25%.

However, there is no literature on the application of the air cavity for riser sleeves. It is a challenge to produce sand molds with air cavity surrounding the riser using traditional molding methods. At present, 3D printing technology is developing rapidly and has been used for sand casting^[11]. In this work, the air cavity surrounding the riser is proposed to realize heat insulation during the solidification process to enhance the feeding effect and prolong the solidification time of risers.

1 Theoretical analysis of heat insulation effect of air cavity

The design of the air cavity surrounding the riser in the

*Jin-wu Kang

Male, born in 1970, Ph.D., Assistant Professor. He has been working in the field of solidification and casting, especially modelling and simulation and 3D printing.
E-mail: kangjw@mail.tsinghua.edu.cn

Received: 2017-12-04; Accepted: 2018-01-22

sand mold is shown schematically in Fig. 1. One-dimensional analysis is carried out to evaluate the insulation effect of the air cavity.

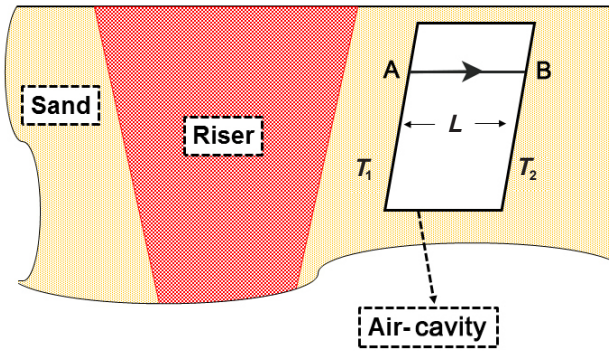

Fig. 1: Sketch diagram of theoretical analysis

If there is no air cavity (the cavity is filled with resin-bonded sand), the heat flux, q_s , is totally determined by heat conduction:

$$q_s = \frac{\lambda_s}{L}(T_1 - T_2) = h_s(T_1 - T_2) \quad (1)$$

where T_1 and T_2 are the temperatures of hot surface T_1 and cold surface T_2 , respectively. λ_s is the thermal conductivity of resin-bonded sand and L is the width of air cavity, h_s is the heat transfer coefficient:

$$h_s = \frac{\lambda_s}{L} \quad (2)$$

For the heat transfer across the air cavity, there is heat conduction, convection and radiation. The heat flux across the air cavity is expressed as follows:

$$q_a = (h_a + h_r + h_c)(T_1 - T_2) \quad (3)$$

where h_a , h_r and h_c are the conduction heat transfer coefficient, radiation heat transfer coefficient and convection heat transfer coefficient, respectively.

The conduction heat transfer coefficient h_a and the radiation heat transfer coefficient, h_r , can be calculated as follows:

$$h_a = \frac{\lambda_a}{L} \quad (4)$$

$$h_r = \frac{\sigma}{\frac{2(1-\varepsilon_s)}{\varepsilon_s} + \frac{1}{F}}(T_1 + T_2)(T_1^2 + T_2^2) \quad (5)$$

where ε_s is the emissivity of gray surface; λ_a is the thermal conductivity of air; F is the view factor between the two surfaces.

Buoyancy flow may develop in the air cavity because thermally induced density gradient occurs between the hot and cold walls, which leads to convection heat transfer. In order to reduce the heat convection flux, the thickness of air cavity (L_{max}), calculated by the Grashoff's law^[12-13], should be designed to avoid natural convection in the air cavity:

$$L_{max} = \frac{1700\nu^2}{(T_1 - T_2)g\alpha P_r} \quad (6)$$

where α is the expansion coefficient of air; g is the gravitational acceleration; P_r is the Prandtl number; ν is the kinematic viscosity of air.

Shangguan et al^[14] did the research on the temperature distribution of a shell-truss sand mold. The measured sand wall temperature surrounding the riser is substituted into Eq. (6). The calculated maximum width of the air cavity is 15 mm.

The ratio ζ of the heat flux with and without air cavity can be given by:

$$\zeta = (h_a + h_r) : h_c \quad (7)$$

According to the temperature field of traditional dense sand mold^[14], the calculated ratios ζ , as shown in Fig. 2, demonstrate that the thermal resistance of the air cavity increases with lowering the inner wall surface temperature T_1 of the internal air cavity. As the hot surface temperature was below 400 °C, the heat flux of the air cavity was around 10% of that of sand mold.

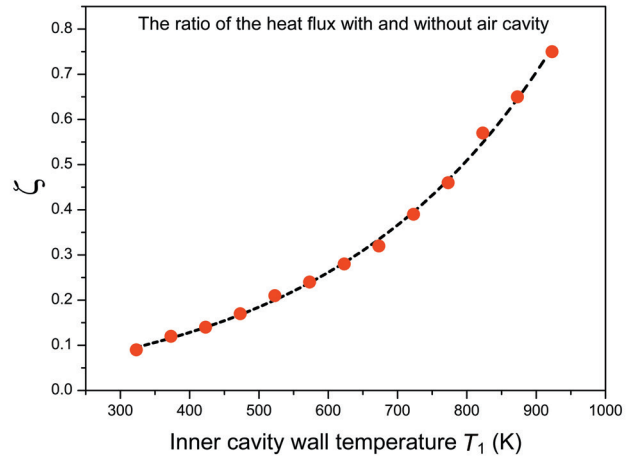

Fig. 2: Calculated value of ζ

2 Numerical simulation

2.1 Molds for simulation

A cylinder casting and a stress-frame casting were utilized for simulation. The design of the mold for cylinder casting is shown in Fig. 3(a). As the maximum width of the air cavity was 15 mm, the width was set as 5, 10, 15 mm to investigate its influence on the insulation effect. Because the radiation heat transfer coefficient of the cavity is affected by the wall temperature of the air cavity, the influence of the wall thickness was studied by three levels of 5, 10, 15 mm, as listed in Table 1. Cast aluminum and steel were simulated for the comparison of the insulation effects for materials with different melting points.

Shangguan et al.^[14] proposed a shell-truss sand mold made by 3D printing technology to increase the cooling rate of the sand mold, and an aluminum alloy casting was obtained. Therefore, to minimize the computation time, this new sand mold was utilized for studying the insulation effect of the air cavity surrounding the riser. The designed shell-truss sand mold is shown in Fig. 3 (b), and the cavity was designed with a 7.5-mm

Table 1: Molds designed for simulation

| Casting | Cavity width L (mm) | Wall thickness D (mm) | Metal |
|--------------|---------------------|-----------------------|---------------------------|
| Cylinder | 5,10,15 | 5,10,15 | Aluminum A356, cast steel |
| Stress-frame | 7.5 | 7.5 | Aluminum A356 |

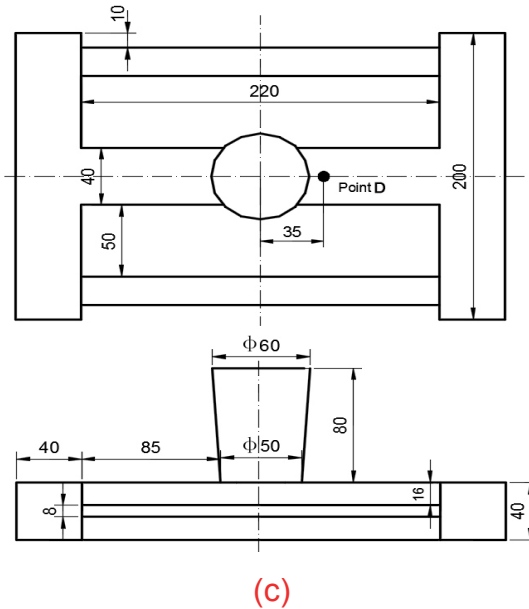
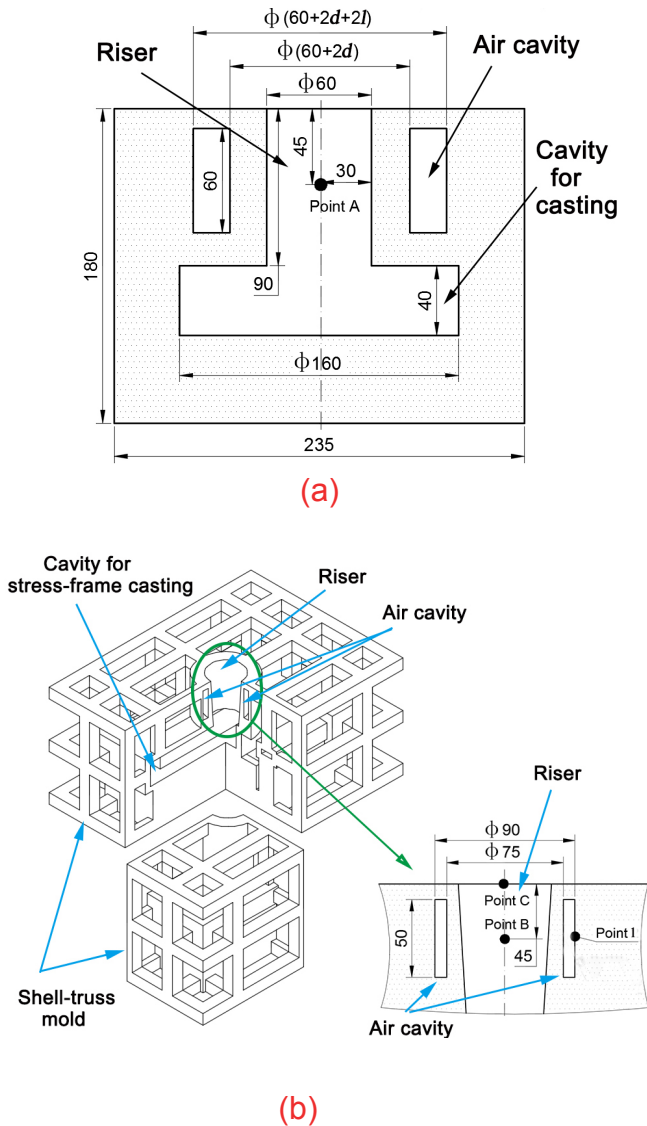

Fig. 3: Molds design for simulation: (a) design of cylinder casting; (b) design of mold for stress-frame casting; (c) geometry of stress-frame casting (unit:mm)

width and a 7.5-mm wall thickness. The geometry of the stress-frame casting is shown in Fig. 3(c).

2.2 Simulation procedure

The numerical simulation of the heat transfer between castings and the mold with air cavity was performed using software COMSOL. The conduction heat transfer was calculated by solving the Fourier equation, and the heat radiation in the air cavity was solved by applying the surface-to-surface radiation as the Eqs. (2) and (4). Convection heat transfer inside the air cavity was neglected as the air cavity width was less than 15 mm.

2.3 Simulation results of cylinder casting

As shown in Fig. 4(a), the cooling curves of point A in Fig. 3(a) show the solidification time of the cast steel melt in the riser

insulated by the air cavity is 572 s, 7.92% longer than that without the air cavity (530 s). The solidification time of the aluminum A356 melt in the riser insulated by the air cavity is prolonged by 9.85% (extended from 711 s to 781 s). As illustrated in Fig. 4(b), the radiation and the conduction heat flux within the air cavity for steel are both higher than that within the air cavity for aluminum A356, since the pouring temperature for steel is always higher than that for aluminum A356. Therefore, the insulation effect of the air cavity is more significant in metal systems with lower pouring temperatures, such as aluminum alloys.

The simulation result for the sand mold for the aluminum cylinder casting shows that the insulation effect is more obvious as the width of the cavity increases [Fig. 4(c)]. However, the insulation effect cannot be significantly improved as the width of the air cavity comes to be less than 10 mm. Figure 4(d) shows that the thinner the wall thickness between the riser and the air cavity, the better the insulation effect. However, this wall thickness has to satisfy the strength requirement to endure the impact of the melt on the riser wall.

The results in [Figs. 4(c,d)] illustrate that the air cavity with 10–15 mm width and wall thickness of 5–10 mm can significantly enhance the insulation effect.

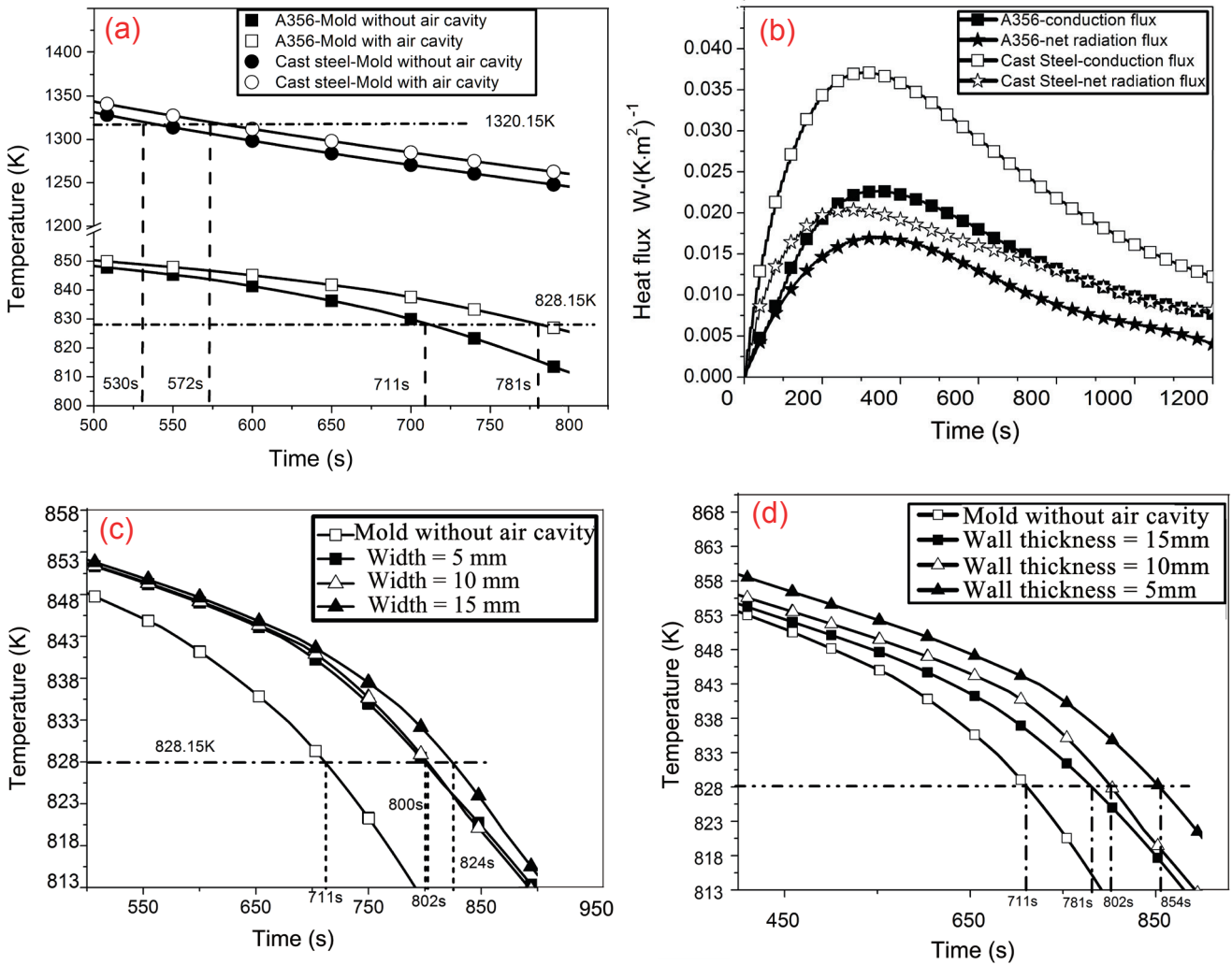
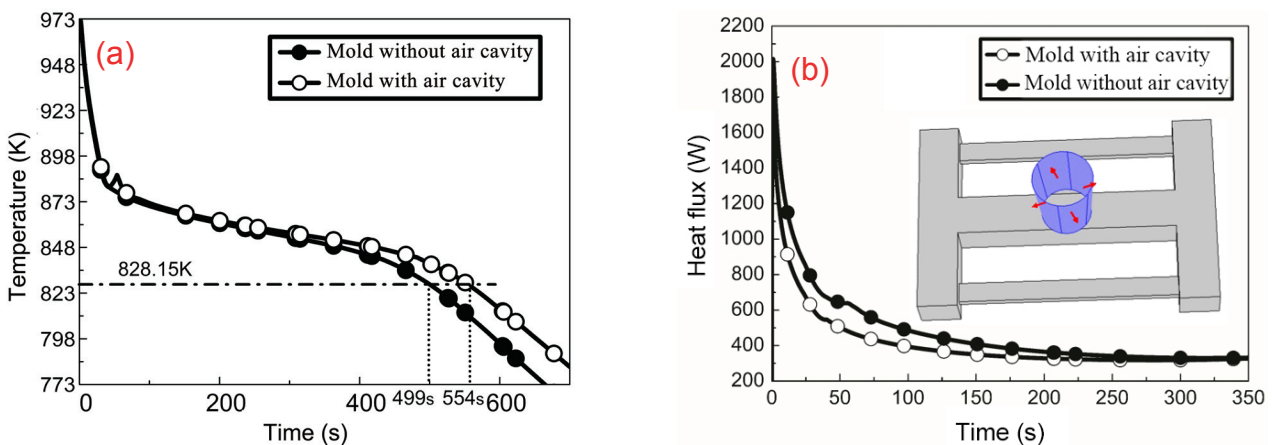

Fig. 4: Simulation results for cylinder casting: (a) solidification time of Point A for different alloys; (b) heat flux within air cavity for different alloys; (c) influence of cavity width on cooling curves of Point A; (d) influence of distance between air cavity and riser on cooling curves of Point A

2.4 Simulation results of stress-frame casting

The simulation results of the aluminum stress-frame casting show the solidification time of Point B in Fig. 3(b) without air cavity is 499 s [Fig. 5(a)], while that in the riser insulated with air cavity is 554 s, with an increase of 11.1 %. The heat flux on

the interface between the riser and sand, as shown in Fig. 5(b), illustrates that the amount of heat flux from the riser into the sand mold insulated by the air cavity is always lower than that into the sand mold without the air cavity. Figure 5(c) shows that the presence of the air cavity increases the temperature of the riser, and decreases the wall temperature of the air cavity at the same time.



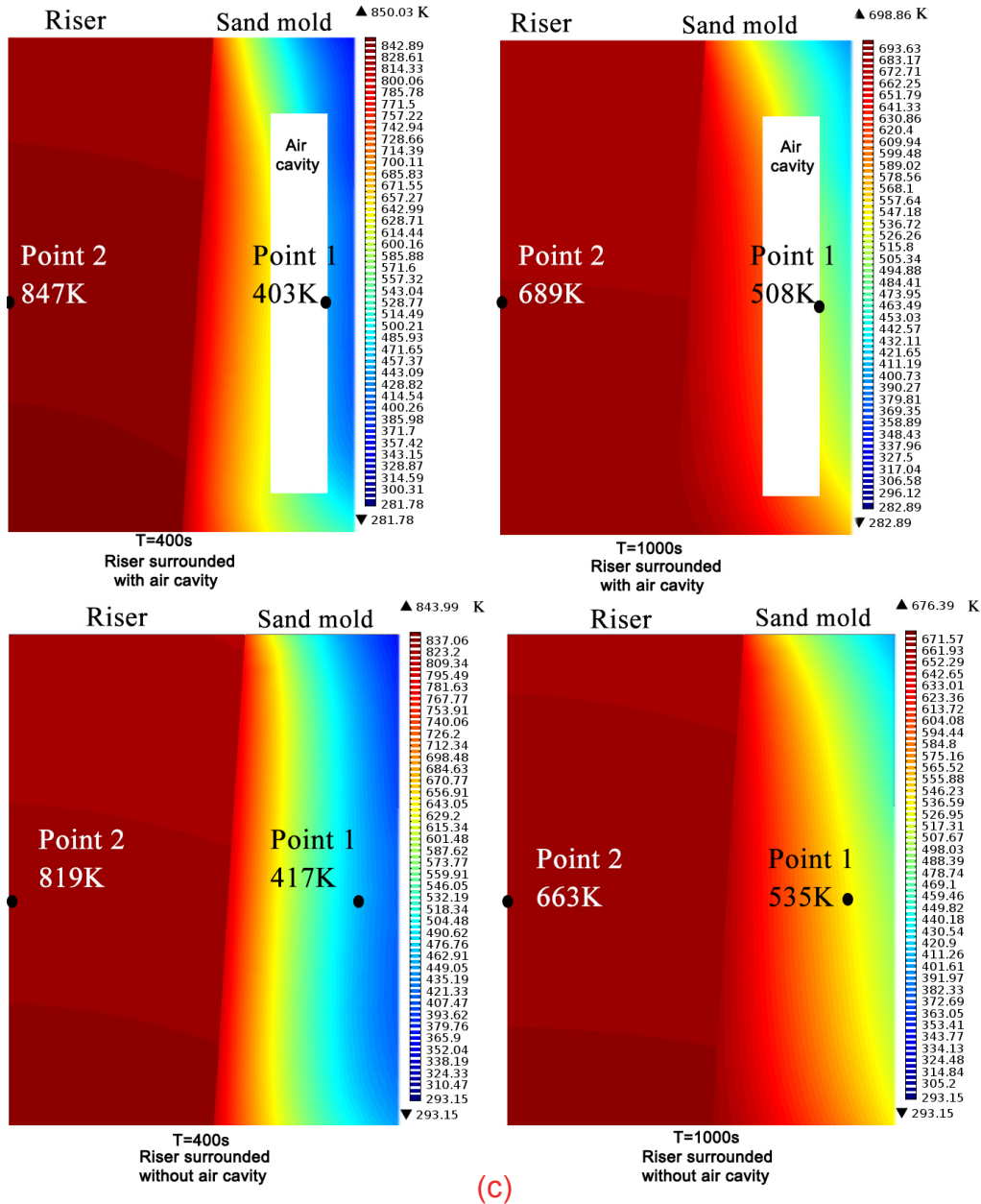

Fig. 5: Simulation results for stress-frame casting: (a) cooling curves of Point B; (b) heat flux flowing out of riser wall; (c) temperature field distribution of half the riser

Therefore, the air cavity can realize an enhanced feeding effect and prolong the solidification time of the molten metal in the riser.

3 Experimental study

3.1 Experimental process

To verify the insulation effect of the air cavity, the stress-frame casting was poured. Figure 6 shows the sand molds with and without the air cavity used for comparison. These were made using a 3D printing machine Max-180 printer (ExOne). The printing process involved the spraying of resin drops through a nozzle onto a dry silica sand bed mixed with a curing agent, furan resin. This standard process was repeated layer by layer.

It was noteworthy that the top of the air cavity of the sand mold was designed as a separate part for convenient removal of loose sand. The cover was placed back to seal the air cavity during the casting process.

The metal for casting was aluminum alloy A356; it was melted in a resistance furnace at 1,000 K (727 °C). Thermocouples were used to measure the wall temperature of the air cavity and an infrared thermal camera was used to measure the surface temperature on the top of the riser.

The strength of 3D printed models made from sand was tested with an average sand strength value of 2.08 MPa. No metal was observed in the air cavity, and the sand wall between the air cavity and the riser was robust, indicating that the wall strength satisfied the pouring requirements for sand.

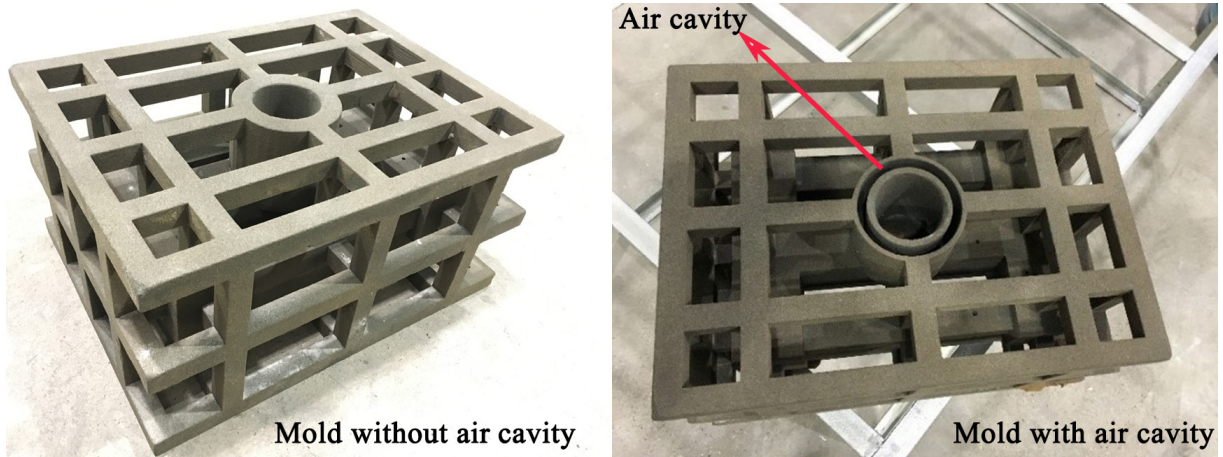

Fig. 6: Molds printed by 3D printing technology

3.2 Experimental results

As shown in Fig. 7(a), the temperatures at point C in Fig. 3(b) illustrates that the temperature of the metal at the top surface in the riser insulated by the air cavity is higher than that in the sand mold without the air cavity after a similar setting time, which indicates that the air cavity has an insulating effect on the riser.

The solidification time of Point D in Fig. 3(c) in the stress-frame casting with the air cavity surrounding the riser is 955 s. This is longer than that in the stress-frame casting without the

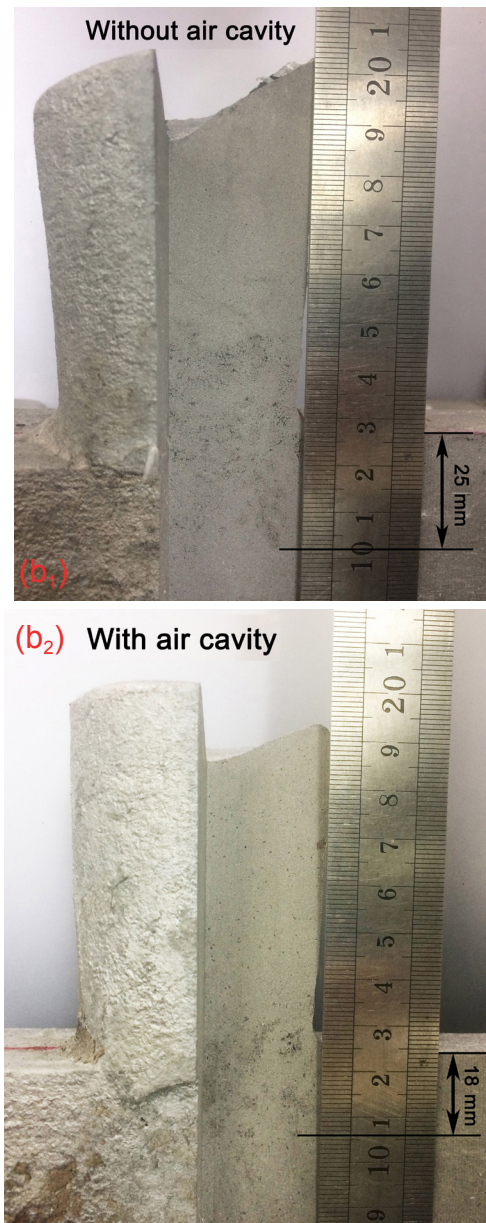
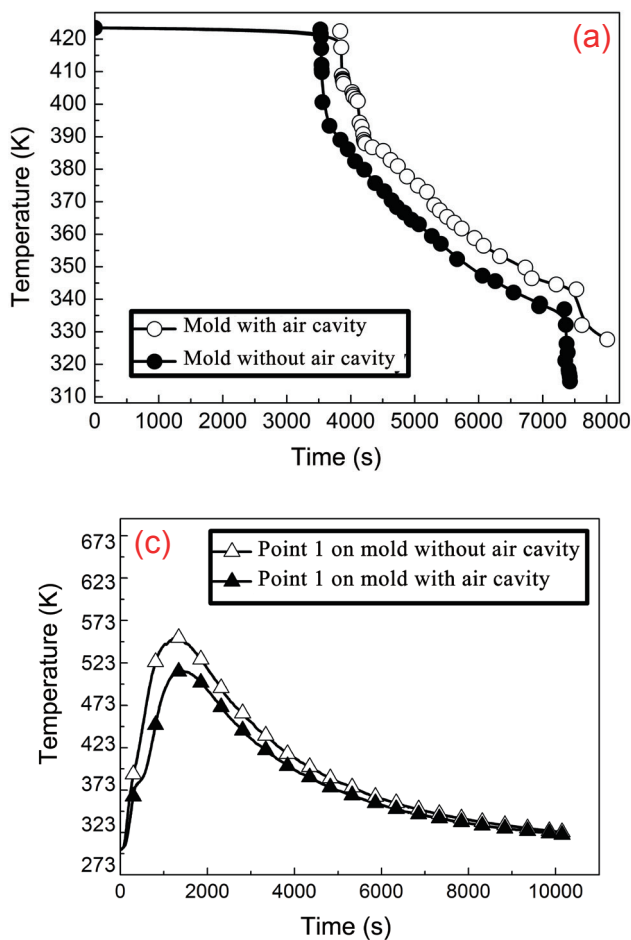

Fig. 7: Experimental results of insulation effect of air cavity on riser: (a) experimental temperature of Point B; (b) results of shrinkage; (c) cooling curves of Point 1

air cavity surrounding the riser (835 s) by approximately 12.5 %.

It can be seen from Fig. 7(b) that the area of shrinkage in the casting is smaller by insulating with the air cavity. The defect zone moves toward the top surface of the riser. For the zone in the casting with the air cavity surrounding the riser, it is 18 mm below the upper surface of casting while that in the casting without the air cavity is 25 mm below.

Figure 7(c) shows that the presence of the air cavity can decrease the wall temperature of the air cavity (Point 1 in Fig. 2b).

4 Conclusions

(1) A sand mold with the air cavity surrounding the riser was proposed to prolong the solidification time of molten metal in the riser and thus enhance its feeding effect. This type of sand mold can be made using 3D printing technology.

(2) The analysis of heat transfer inside the air cavity indicates that the sand mold with the air cavity is more effective for alloys with a lower melting point, such as aluminum alloys.

(3) The insulation effect increases with increasing width of the cavity and decreasing the thickness of the wall between the riser and the cavity.

(4) The sand mold with the air cavity prolongs the solidification time of the melt in the riser by over 10% for a stress frame casting.

References

- [1] Chudzik S, Minkina W. An Idea of a Measurement System for Determining Thermal Parameters of Heat Insulation Materials. *Metrology & Measurement Systems*, 2011, 18(2): 261–274.
- [2] Latifi M, Chaouki J. A novel Induction Heating Fluidized Bed Reactor for Screening Tests of Solid Feedstocks. *Aiche Journal*, 2015, 61(5): 1507–1523.
- [3] Shafe A A and Azadur Rahman A H M. Development of small scale low cost insulating riser sleeves from scraps and by products of an existing foundry industry. *International Journal of Innovative Science and Modern Engineering*, 2015, 3: 1–3.
- [4] Hussainy S F, Mohiuddin M V, Laxminarayana P, et al. Analysis of Shrinkage Characteristics of Aluminium Silicon Alloy. *Journal for Manufacturing Science & Production*, 2016, 16(3): 163–171.
- [5] Hardin R A, Williams T J and Beckermann C. Riser Sleeve Properties for Steel Castings and the Effect of Sleeve Type on Casting Yield. In: *Proceedings of the 67th SFSA Technical and Operating Conference, Steel Founders' Society of America*, Chicago IL, 2013: 1–18.
- [6] Song Zhongxun. Development and study of heat insulation riser sleeve for casting. Ph.D. dissertation, Huazhong University of Science and Technology, Wuhan, China, 2007: 38–41. (In Chinese)
- [7] Jin C K, Seo H Y, Kang C G. Heating system for riser size minimizing in sand casting process and its experimental verification. *Metals*, 2017, 130(7): 1–12.
- [8] Li L P, Wu Z G, He Y L, et al. Optimization of the configuration of 290 × 140 × 90 hollow clay bricks with 3-D numerical simulation by finite volume method. *Energy & Buildings*, 2008, 40(10): 1790–1798.
- [9] Al-Sanea S A, Zedan M F. Effect of insulation location on thermal performance of building walls under steady periodic conditions. *International Journal of Ambient Energy*, 2001, 22(2): 59–72.
- [10] Tong T W, Gerner F M. Natural convection in partitioned air-filled rectangular enclosures. *International Communications in Heat & Mass Transfer*, 1986, 13(1): 99–108.
- [11] Almaghariz E S, Conner B P, Lenner L, et al. Quantifying the Role of Part Design Complexity in Using 3D Sand Printing for Molds and Cores. *International Journal of Metalcasting*, 2016, 10(3): 240–252.
- [12] Zhao Zhennan. Heat transfer, 2nd ed. Beijing, China: Higher Education Press, 2002. (In Chinese)
- [13] Zhang Ximin, Ren Zelin, and Mei Feiming, Heat transfer, 5th ed. Beijing, China: China Architecture and Building Press, 2007. (In Chinese)
- [14] Shangguan Haolong, Kang Jinwu, Deng Chengyang, et al. 3D-printed shell-truss sand mold for aluminum castings. *Journal of Materials Processing Technology*, 2017, 250: 247–253

This research study was funded by the National Science and Technology Major Project of the Ministry of Science and Technology of China under Project No. 2016YFB1100703.
